

TC CONTROL LEVER

Part Number: 31001 TC Single Lever (Throttle Control)
31002 TC Single Lever (Clutch Control)
36468 TC Twin Lever (Clutch & Throttle Control)
36469 TC Twin Lever (Throttle & Throttle Control)

OWNER'S MANUAL Installation, Operation and Maintenance Instructions

PLEASE READ THESE INSTRUCTIONS CAREFULLY
BEFORE INSTALLING OR OPERATING THIS CONTROL

ALL SPECIFICATIONS AND FEATURES ARE SUBJECT TO CHANGE WITHOUT NOTICE

INTRODUCTION

The TC Control is a heavy-duty unit with a positive brake and shut off position for heavy throttles (governors). The throttle lever, a red knob, can activate the brake by turning in a clockwise direction. The clutch lever, a black knob, has a detent so that the operator can feel the positions of neutral, forward, and reverse.

TWIN LEVER INSTALLATION

1. Control Head Mounting Position

After location of the control head is determined, use the template provided (in page 7) to cut and drill the mounting holes required 6.0 mm (1/4"). The mounting position should be so selected that the control levers can be freely operated and the control cable can be bent at a radius of more than 200.0 mm (8.0") when it is routed.

2. Cable Routing

Insert the cables into the control head mounting hole and route them to the engine.

Figure 1.

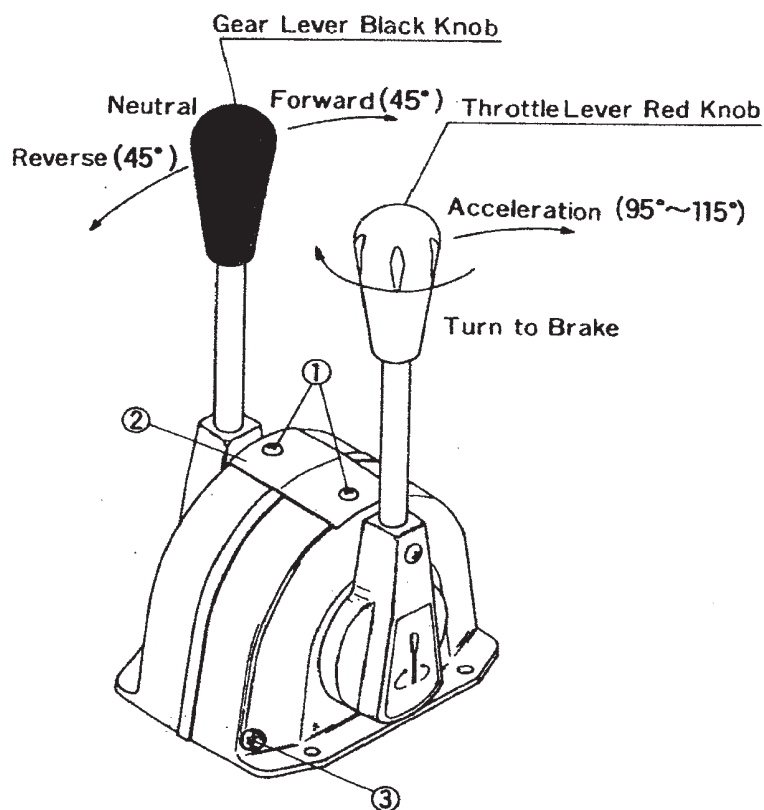

3. Clutch Cable Installation

- 1) Determine the clutch lever position for right hand or left hand according to your preference.
- 2) Remove screws both ① and ③, and open the control head. (See Figure 1)
- 3) Remove support plate ⑤. (See Figure 3)
- 4) Having determined the amount of travel required to operate the clutch lever, select the corresponding mounting hole. (See Figure 2)
- 5) Screw on the terminal ⑥ (contained in the parts bag) over the cable threads and fasten with the locking nut as illustrated in (Figure 4).
- 6) Grease pin ⑦ and washer ⑧ (contained in the parts bag) as shown in (Figure 3). Connect the cable to operating shaft ⑨. Tighten screws ④ firmly.
- 7) Secure the cable to hanger plate of the control head using screws ⑩, clamp ⑪ and shim ⑫ (contained in the parts bag). (See Figure 5)

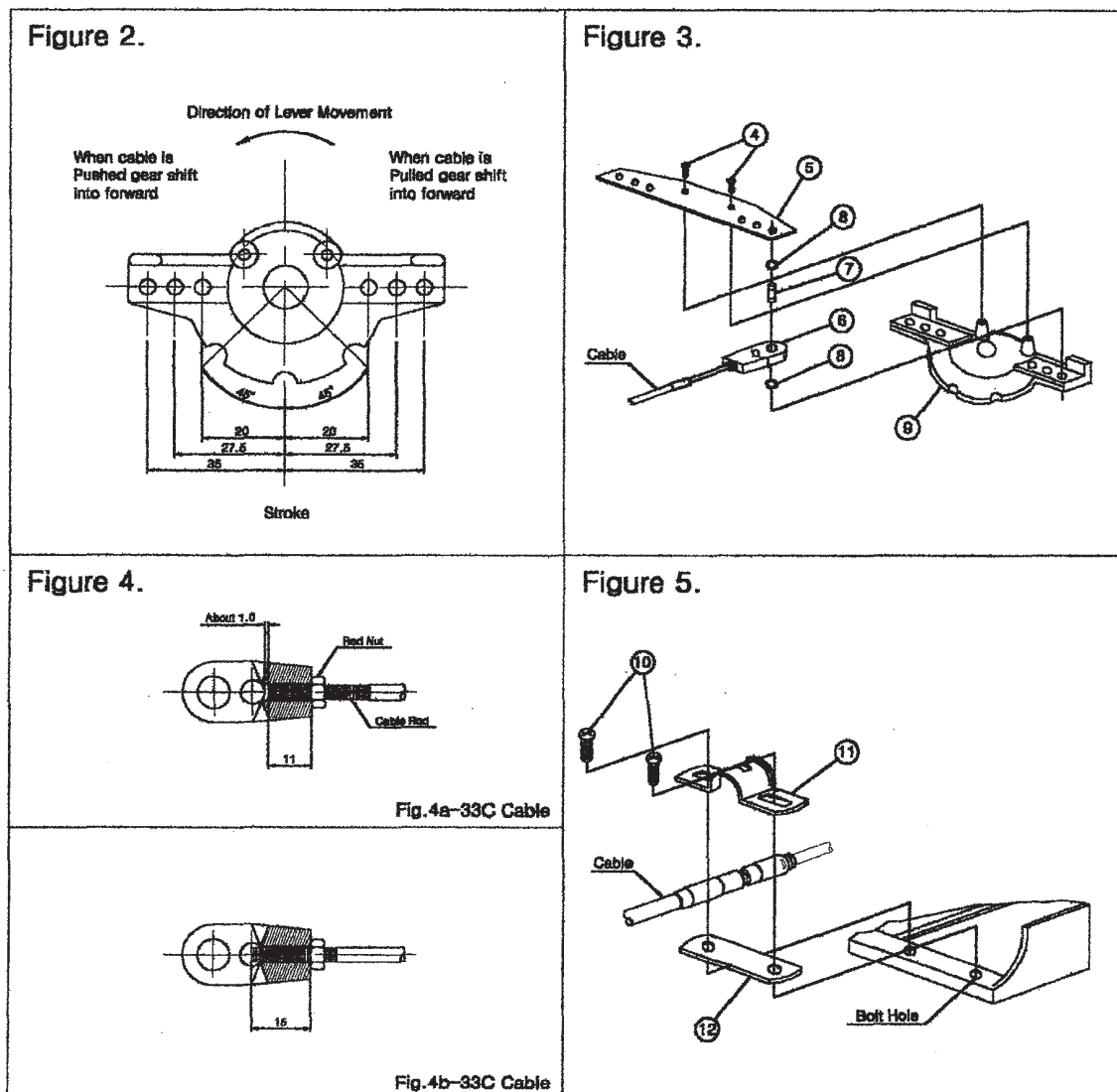

4. Throttle Cable Installation

The throttle cable can be installed in the same manner as the clutch cable. By referring to “3. Clutch Cable Installation” and (See Figure 6), install the throttle cable.

5. Control Head Assembly

Put together both control head halves on the clutch and throttle sides and replace the screws ③, which were removed in (Figure 1), then place the control head in the mounting hole.

NOTE: DO NOT INSTALL SCREWS ① AND COVER PLATE ②. DO NOT SECURE THE CONTROL HEAD TO THE MOUNTING HOLE AT THIS STATE.

6. Connecting the Cable to the Engine

- 1) When connecting the gearshift cable to the engine, be sure to set the control lever and gear box in “neutral”.
- 2) When connecting the throttle cable, place both the control lever and engine in “idle”.

NOTE: AVOID BENDING THE CABLE TO A RADIUS OF LESS THAN 200.0 mm (8.0”).

7. Adjustment and Inspection

- 1) By moving the control head clutch lever a few times, check to see if both the control lever and the engine clutch are in the corresponding positions (neutral/forward/backward). If not, make an adjustment by changing the position of the cable in operating lever or by altering the position of the terminal ⑥ in relation to the thread on the cable or both.
- 2) By opening the control head throttle lever, make sure that the throttle fully opens and closes correctly. If not, make an adjustment by turning adjust screw ⑬ (See Figure 7). After adjustment, tighten nut ⑭ firmly.
- 3) Secure cover plate ② to the control head using screws.
- 4) Make sure all screws and nuts are securely tightened.

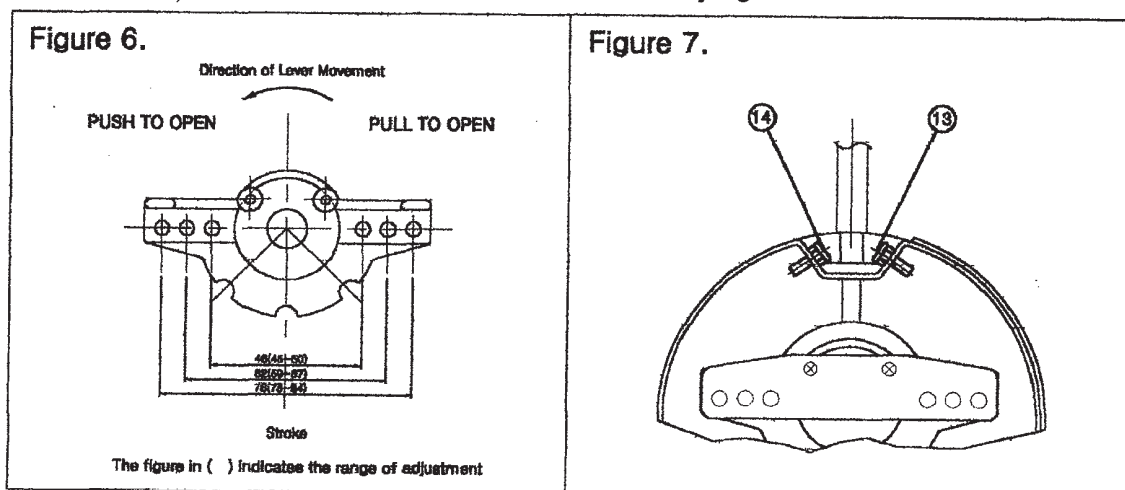

SINGLE LEVER INSTALLATION

The Single Lever can be installed in the same manner as the Twin Lever. To install the Single Lever, just follow Step 1 through Step 8 on previous pages.

DUAL STATION INSTALLATION

The dual station (the system to control a single engine from two control heads installed separately) can be installed in the following three ways (A, B, or C).

To install, first connect the main-control head to the engine and then connect the main control head to the sub-control head. This procedure applies to all the three (A, B, or C) ways of installation.

To install the dual station in A or B way, first remove the detent from the sub-control head. In the case of A, the attachment kit shown in Table 1 is required to. To install B or C way, consult the dealer from whom you purchased the control head.

The Table 1 applies to the 3C series cable. When the 4C series cable is used, consult the dealer from whom you purchased the control head.

Table 1: Attachment Kit

For the use of 3C Cable

ITEM	CABLE ADAPTER KITS
SINGLE LEVER	PT 10113
TWIN LEVER	PT 20213

Table 2: Attachment Kit and Part No.

For the use of 4C Cable

ITEM	CABLE ADAPTER KITS
SINGLE LEVER	PT 10114
TWIN LEVER	PT 20214

Figure 8.

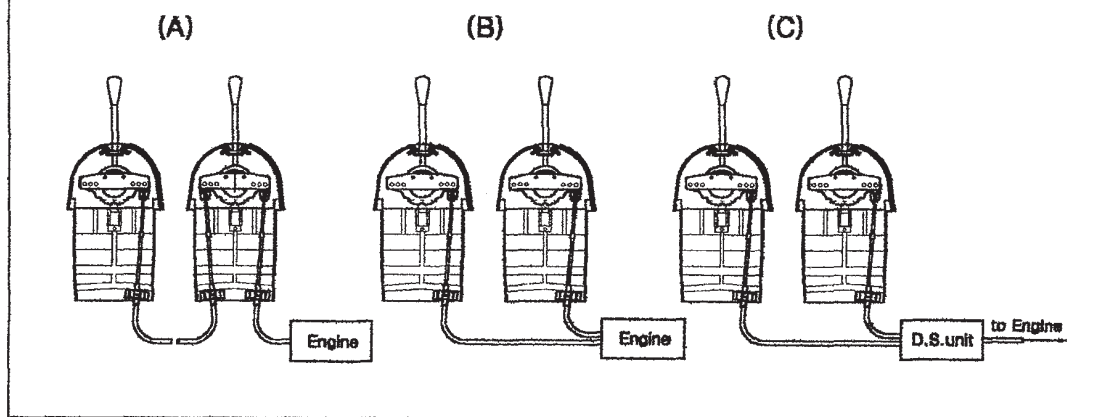

HOW TO CHANGE THE LEVER MOUNTING ANGLE

Remove the control head from the mounting hole, then place the lever in a vertical position and insert a 4.0 mm hexagon wrench into the hole in the housing flange. Loosen the screw ¹⁵ holding the lever to the shaft and then remove the lever.

Since the lever is fitted to the shaft by means of a spine, the lever angle can be easily changed. Be sure to tighten the screw ¹⁶ securely after the lever is inserted in the desired position. (See Figure 9)

ROUTINE CARE

To maintain a longer service life, routine care is most important, particularly when the control head is exposed to the salt water. Coating of wax, rust inhibitor, grease or oil will help keep the control head in good condition.

Figure 9.

